

ZERMA

THE HOME OF SIZE REDUCTION

Shredders // **Granulators** // Pulverizers // Accessories

GSL // GSE // GSC // **GSH** // GSP // ZHM

GSH 600-700 HEAVY DUTY GRANULATOR

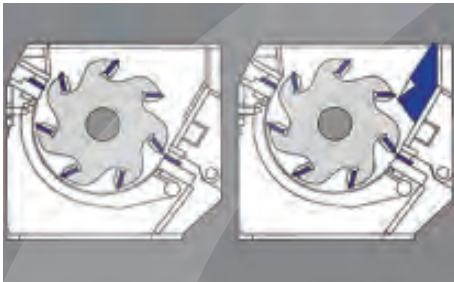

The easily removable deflector wedge acts as a third stator blade and can be used to adjust the aggressiveness of the rotor at the first cutting point.



The GSH granulators are available with different rotor options to fit different applications, all rotors feature the V-cut technology creating a high quality regrind.



The heavy duty bearings are separated from the cutting chamber to avoid lubricants entering the cutting chamber and bearing failure due to material contamination in the bearings.

GENERAL DESCRIPTION

The heavy duty granulators of the GSH 600 and 700 series offer a wide array of different rotor designs with widths ranging from 800 mm to 1000 mm with a diameter of 600 and 700 mm. The completely welded heavy steel construction is designed to withstand the most demanding and universal applications. Rotor bearings, knife mounts and rotor shaft are oversized. The standard V-cut creates a high quality regrind with a very low percentage of fines in the output material. The removable third stator blade is acting as a deflector wedge and allows the machine to be quickly adjusted to different application scenarios. Other standard features include easily replaceable wear plates in the cutting chamber as well as outboard bearings reducing the risk of contamination.

APPLICATIONS

The wide range of rotors and hopper styles allow the GSH machines to be tailored to almost every application in the plastic recycling field. The GSH 600 and 700 granulators are mainly used as large central granulators for in house recycling applications to process large thick walled parts in one step or as a second step granulator after a shredder to reach higher throughput rates. When used to grind light materials, such as bottles the throughput can be greatly increased with the addition of a ZERMA force feeding device. For abrasive, contaminated or highly filled materials the machines can be equipped with special wear protections, such as hard facing of the rotor and housing and key parts manufactured from highly wear resistant steels.

ADVANTAGES

- **Knives are adjusted outside of the machine**
- **Specially developed deflector wedge**
- **Wide choice of rotors**
- **Well thought out housing design**
- **Strong Welded Steel construction**
- **Oversized outboard bearings**

ENGLISH

PLASTIC SIZE REDUCTION
RUBBER SIZE REDUCTION
WOOD SIZE REDUCTION
E-WASTE SIZE REDUCTION



ZERMA

GSH

HEAVY DUTY GRANULATOR



ZERMA. THE HOME OF SIZE REDUCTION



PLASTIC SIZE REDUCTION

RUBBER SIZE REDUCTION

WOOD SIZE REDUCTION

E-WASTE SIZE REDUCTION

SPECIFICATIONS

Type GSH	600/800	700/1000
Rotor diameter (mm)	600	700
Rotor width (mm)	800	1000
Drive capacity (kW)	75	90
Rotor knives (rows)	5 or 7	5 or 7 or 9
Stator blades (rows)	2 or 3	2 or 3
Screen size (mm)	>6	>8
Effective working area (mm)	790 x 695	900 x 800
A (mm)	2350	2815
B (mm)	2100	2500
C (mm)	1000	1100
D (mm)	1940	2250
E (mm)	788	985
F (mm)	1125	1290
G (mm)	1840	2060

DIMENSIONS

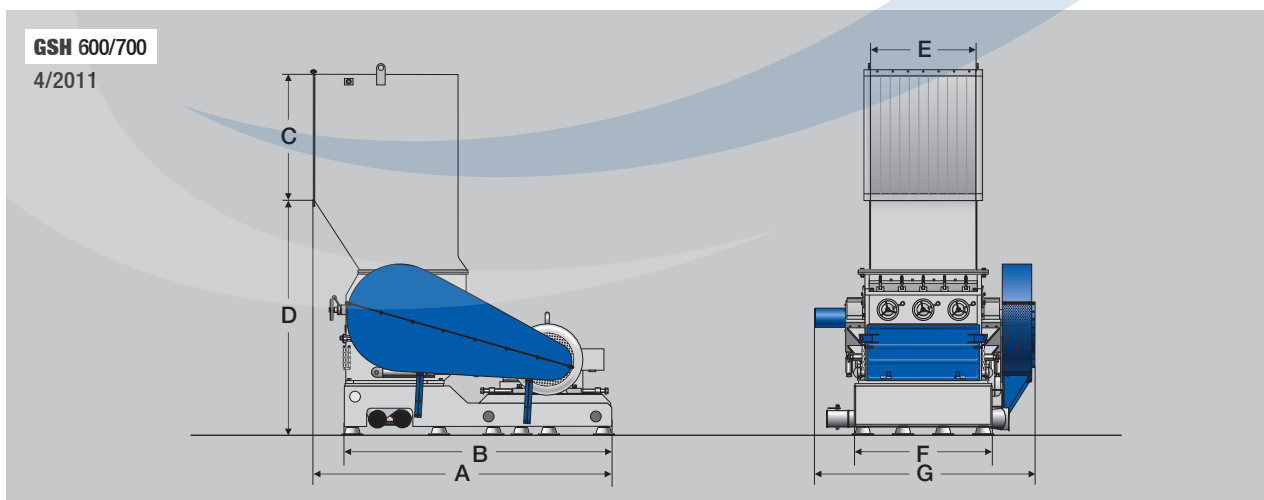

5 Xinjie Rd XinQiao Township Ind. Park, Songjiang Shanghai,
 Zip: 201612, China
 PHONE: +86 21 57645573 FAX: +86 21 57646766
 E-MAIL: INFO@ZERMA.COM

ZERMA MACHINERY & RECYCLING TECHNOLOGY CO. LTD.
 SHANGHAI CHINA

WWW.ZERMA.COM

Subject to technical modification