



**JST ENGINEERING CO.,LTD.**

78/6 MOO 7 KING KAEW RD., RACHATEWA,  
BANGPLEE, SAMUTPRAKARN 10540 THAILAND.

TEL: +66 (0) 2738 5050-4

URL: [www.jst.co.th](http://www.jst.co.th)

FAX: +66 (0) 2738 5055

LINE ID: @jst.co.th

E-mail: [info@jst.co.th](mailto:info@jst.co.th)

[www.facebook.com/jst.co.th](https://www.facebook.com/jst.co.th)

## Mold Sweat Dehumidifier

SMD-2000H



Refer carefully to this manual before operation.

# SMD-H Series

## ■ Coding Principle

SMD - xxx H

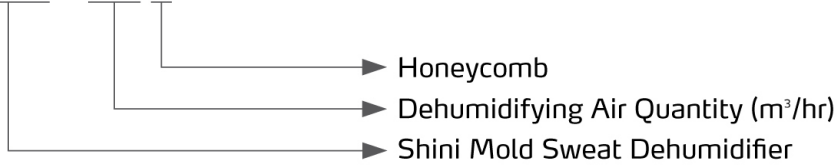

## ■ Features

- Adopts P.I.D. temperature control system; can set regenerative temp. and have display screen of actual temp.
- Honeycomb rotor is used to ensure constant air dehumidifying effect.
- With main power switch, it ensures safety of operation and maintenance.
- Motor overload and phase reverse alarm functions are provided.
- Return air cooling and filtering are provided.
- Under normal atmospheric conditions, the air humidity can be controlled precisely all year round.
- Prolong service life of mold, reduce corrosion, and yet reduce product flaws and defective product rate.
- Cooler is standard equipped at the drying air outlet, which can adjust the temperature of outlet air.
- It has water auto-drainage function which can remove the condensed water out of the machine.

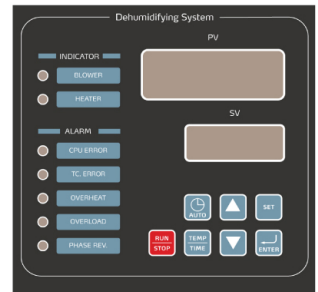

Control Panel

## ■ Application

SMD series mould sweat dehumidifiers are designed to remove moisture sweat from condensing on mold surface. Moisture condensation on the mold surface is due to the use of chilled water for reducing molding cycle time, particularly while molding PET preform. When mold surface temperature is lower than dew-point temperature of surrounding air, the water vapor comes into being, which leads to moisture condensation, and then affect product quality and production efficiency as well as bring corrosion to the mold surface and cause environmental pollution. This series of machine uses honeycomb rotor to carry out dehumidifying function, which provides constant low dew-point drying air for the molding machine. It greatly reduces the reject ratio by making mold out from moisture condensation.

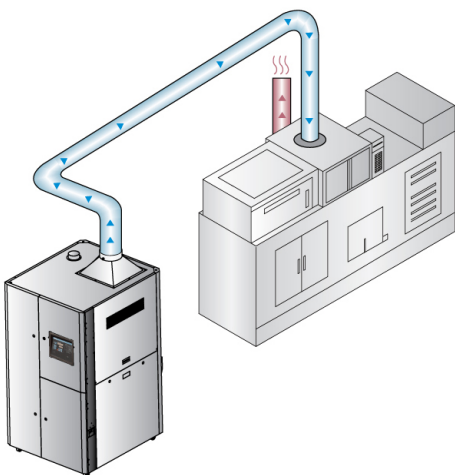

Open-loop Air Circulation

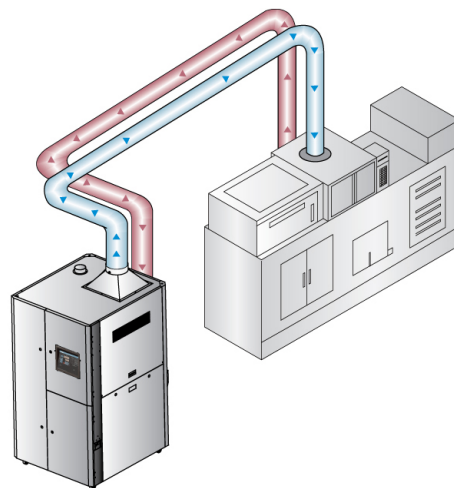

Closed-loop Air Circulation

## Options

- Detachable return air collector is optional to achieve closed-loop circulation which is specially suitable for high humidity areas. Add "R" at the end of the model code.
- Optional dew-point monitor, add "D" at the end of the model code.

## Working Principle

The large amount of air created by centrifugal blower will be directly blown to the models of IMM after being moisture absorbed by rotatory honeycomb and becoming dry air of low dew-point. Then air discharges through air outlet of mold closing chamber and returns to mold sweat dehumidifier through return air pipe. In this way, a circle finished.

The air around mold is very dry with dew-point no higher than 5°C. Environmental temperature drops fast during the rapid mold cooling, but temp. will not fall to 5°C. Therefore, dewdrop will not come into being during mold rapid-cooling, which ensures product quality.

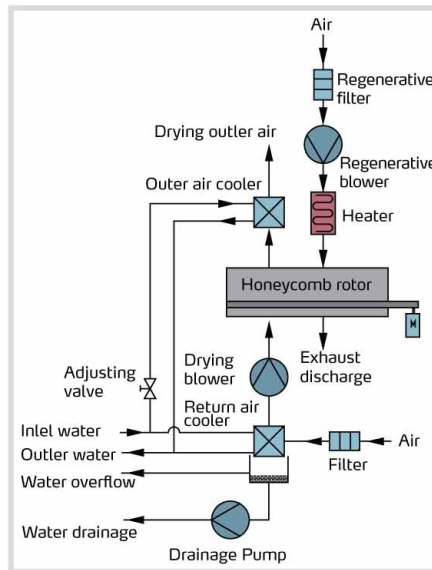

## Outline Drawings



## Specifications

Model	Regen. Heater (kW)	Regen. Blower (kW) (50 / 60Hz)	Process Blower (kW) (50 / 60Hz)	Process Air Flow (m <sup>3</sup> /hr)	Pipe dia. of dry air (inch)	Pipe dia. of regeneration air (inch)	Water Connection	Ave. Process Air Temperature (°C)	Dew-point Temp (°C)	Cooling Water Flow (L / min)	Cooling Water Pressure (kgf / cm <sup>2</sup> )	Dimensions (mm) H × W × D	Weight (kg)
SMD-1000H	12	0.25	1.1	1,000	8	4	1½" PT (Female)	≤16	-10~+5	≥100	1-5	1940×960×1100	321
SMD-2000H	24	0.55	2.2	2,000	10	6	1½" PT (Female)	≤16	-10~+5	≥150	1-5	2410×1130×1295	580
SMD-3000H	30	0.75	3	3,000	10	6	2½" PT (Female)	≤16	-10~+5	≥190	1-5	2775×1225×1295	700

Notes: 1) Noise level ≤90dB (A).

2) Condition for Open-loop application: Ambient dry bulb temp. ≤30°C, relative moisture ≤70%.

3) Cooling water required temp.: 7°C.

4) Power: 3Φ, 230 / 400 / 460 / 575VAC, 50 / 60Hz.

We reserve the right to change specifications without prior notice.