



JST ENGINEERING CO.,LTD.

78/6 MOO 7 KING KAEW RD., RACHATEWA,
BANGPLEE, SAMUTPRAKARN 10540 THAILAND.

TEL: +66 (0) 2738 5050-4 URL: www.jst.co.th

FAX: +66 (0) 2738 5055 LINE ID: @jst.co.th

E-mail: info@jst.co.th www.facebook.com/jst.co.th

Volumetric Ratio of Two Feed Mixer

SVTM-60-360



Refer carefully to this manual before operation.

SVTM Series

■ Coding Principle

SVTM -XX-XX-XX

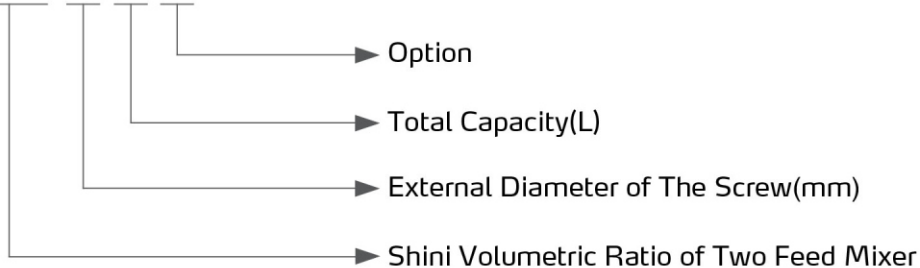

■ Features

- Adopt SUS 430 material hopper
- The main body divides into two storage hoppers: hopper 1 at left, hopper 2 at right.
- Both SMH and SAL are available to amount on the two hoppers.
- Employ two gear motors separately to convey the material.
- Low noise, high accuracy and stability.
- Stainless steel screw ensures no material contamination.
- The suction box is able to connect with external hopper loader for material output.



Control Panel

■ Application

It is mainly applicable for occasions such as different proportional mixing of virgin and recycled materials, or two different materials.

■ Options

Low Level Switch

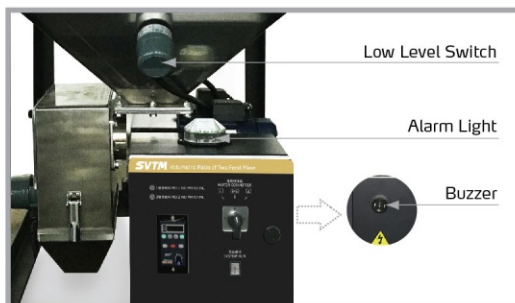

Low level sensor collocated with indicator and buzzer is available to send shortage alarm in advance. Add "FAD" at the end of the model code

Working Principle

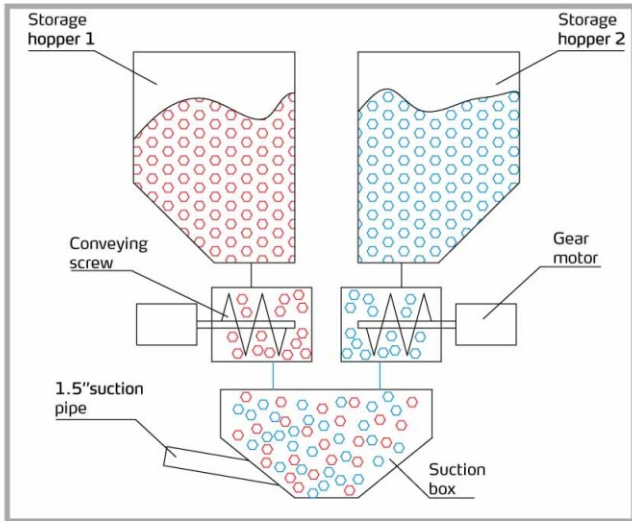

The storage hoppers can store two different materials:

After switch turns to the 1st gear, motor No.1 starts to work while motor No.2 is idle. The screw begins to convey the material in hopper No.1;

After switch turns to the 2nd gear, motor No.2 starts to work while motor No.1 is idle. The screw begins to convey the material in hopper No.2;

After switch turns to gear 1+2, motor No.1 and No.2 start to work simultaneously. Adjust the speed of motor No.2 via touch panel, by control the speed ratio of the two motors to control the output proportion of the two materials.

Outline Drawings

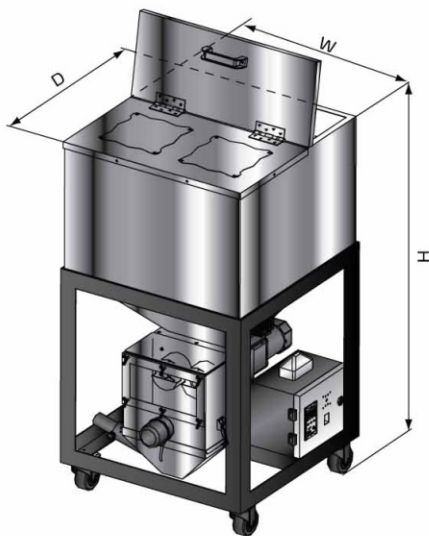

Dimension of hopper cover

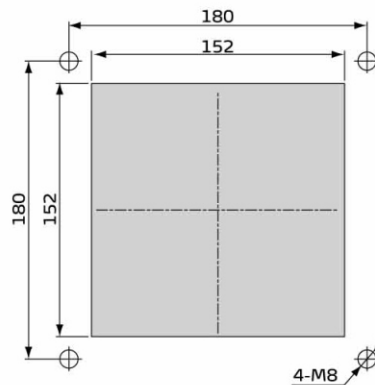

Specifications

Model	Motor Power 1 (kW)	Motor Power 2 (kW)	Screw External Dia.(mm)	Storage Hopper 1 (L)	Storage Hopper 2 (L)	No.1 motor processing capacity (kg/h)	No.2 motor processing capacity (kg/h)	Dimension (HxWxD)	Weight (kg)	Pipe Dia. (inch)
SVTM-60-180	0.09	0.09	60	90	90	469.6	27.2~423	1130×620×620	80	1.5
SVTM-60-360	0.09	0.09	60	180	180	469.6	27.2~423	1230×850×850	100	1.5
SVTM-60-720	0.09	0.09	60	360	360	469.6	27.2~423	1480×1000×1000	150	1.5
SVTM-80-1200	0.12	0.12	80	600	600	798.8	43.5~676.8	1700×1220×1220	190	2.0

Notes:1) Test condition of conveying capacity: plastic material of bulk density 0.65kg/L, dia. 3~5mm.

2) wer supply: 1Φ, 220VAC, 50Hz .

We reserve the right to change specifications without prior notice.