

## Sliding Air Cutters

### VERTICAL TYPE

# MF Type

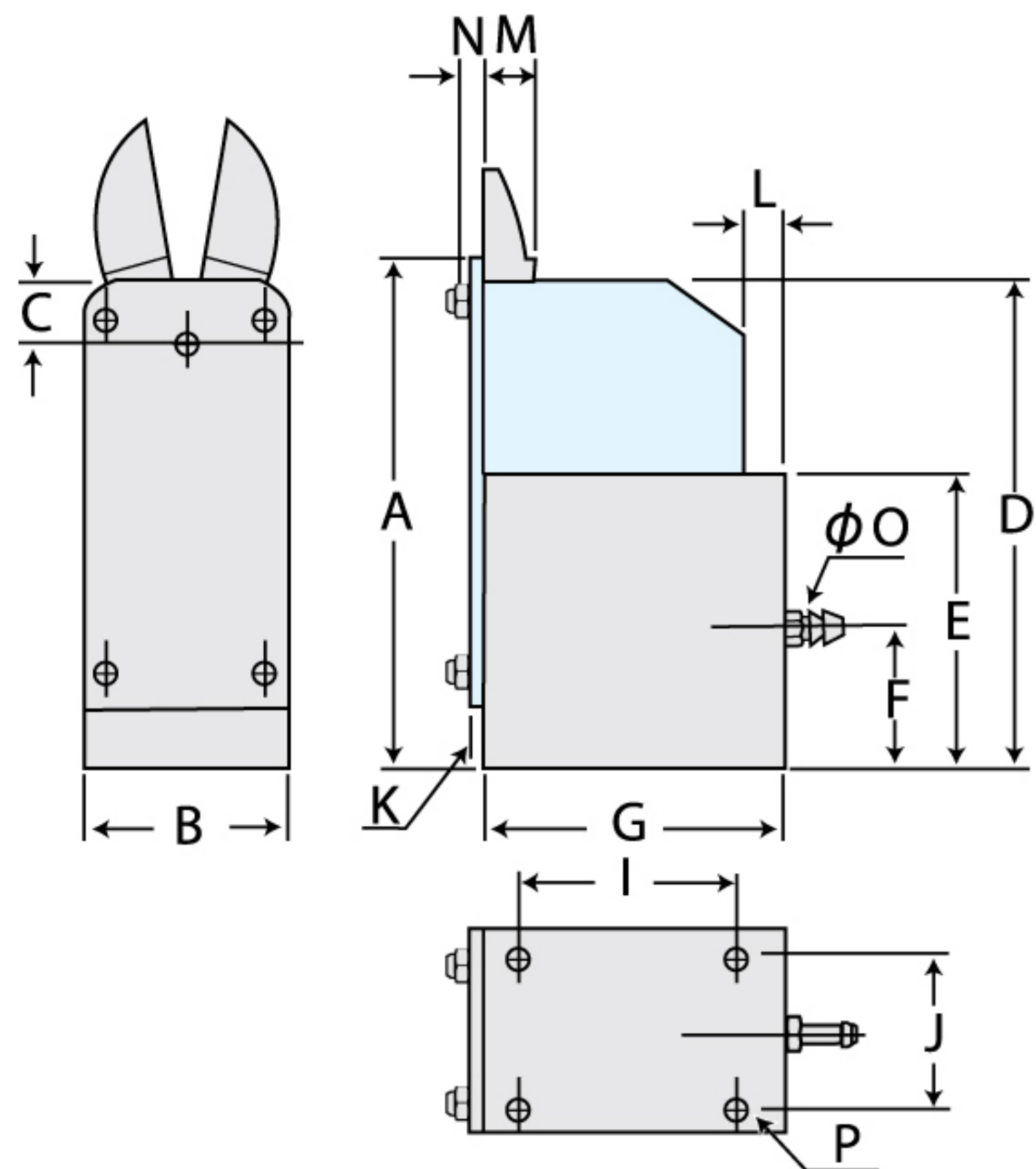

#### MF type specification

Model (less blade)	Weight (g)	Air consumption (cm <sup>3</sup> /stroke)	Air pressure (MPa)	Blade	Plastic (φmm)	Dimensions (mm)														
						A	B	C	D	E	F	G	I	J	K	L	M	N	O	P
<b>MF3</b>	71	12	0.4~0.5	F10E,F10EK	1.0	71	20	8	68	40	10	38	25	14	2	10	7	3.3	4	M4/D10
<b>MF5</b>	73	28	0.4~0.5	F1E,F1EK	1.2	73	29	9	69	41	20	44	30	22	2	7	7	4.0	4	M4/D10
<b>MF10</b>	96	65	0.4~0.5	F3E,F3EK	2.5	96	35	10	91	56	20	53	40	26	2	8	9	4.0	4	M4/D15
<b>MF20</b>	110	122	0.5~0.6	F5E,F5EK	4.5	110	44	13	102	60	20	64	45	34	2	13	12	3.0	4	M4/D15

Blade	(mm)			
	a	b	c	d
F10E, F10EK	24	13	3.5	7
F1E, F1EK	24	12	5.5	7
F3E, F3EK	27	13	7	9
F5E, F5EK	35	18	9	12

