



Sound-proof Central Granulator



JST ENGINEERING CO.,LTD.

78/6 MOO 7 KING KAEW RD., RACHATEWA,
BANGPLEE, SAMUTPRAKARN 10540 THAILAND.

TEL: +66 (0) 2738 5050-4

URL: www.jst.co.th

FAX: +66 (0) 2738 5055

LINE ID: @jst.co.th

E-mail: info@jst.co.th

www.facebook.com/jst.co.th

SG-4390

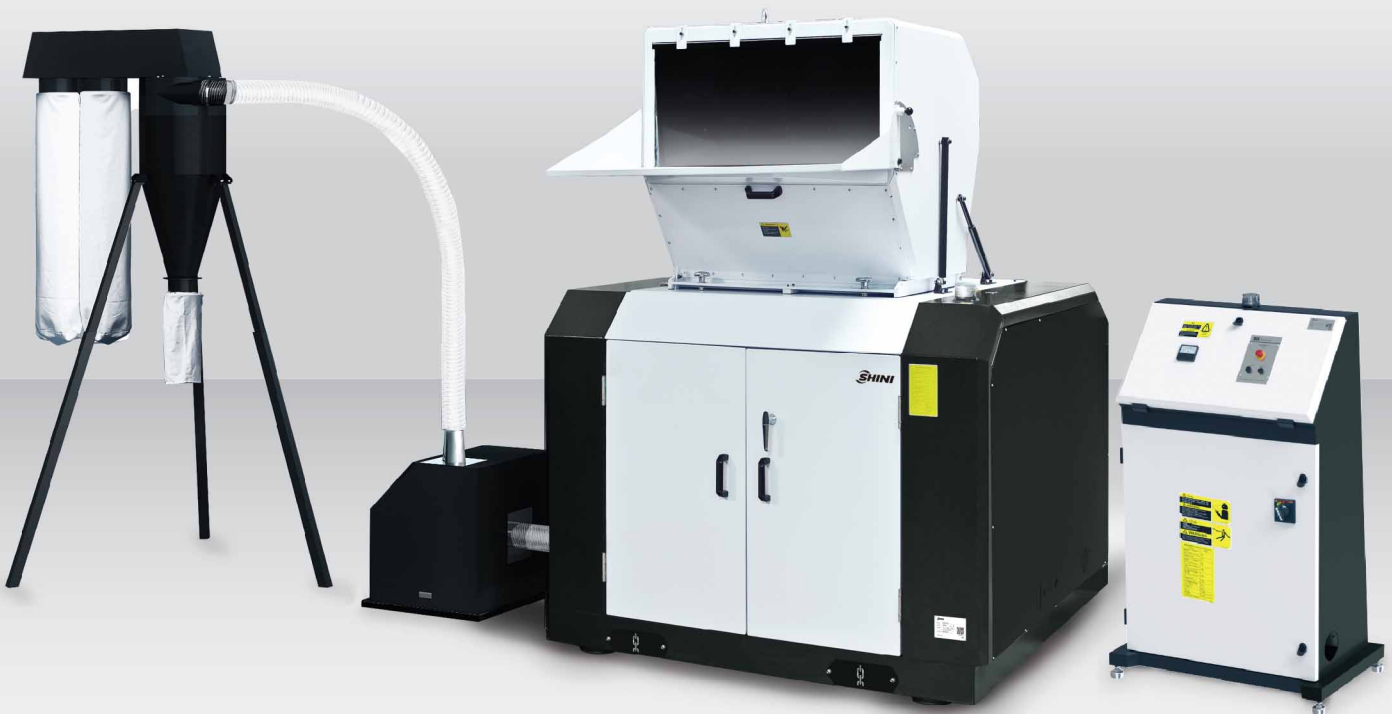

Refer carefully to this manual before operation.

SG-43/50/70 Series

■ Coding Principle

SG - xx xx - x

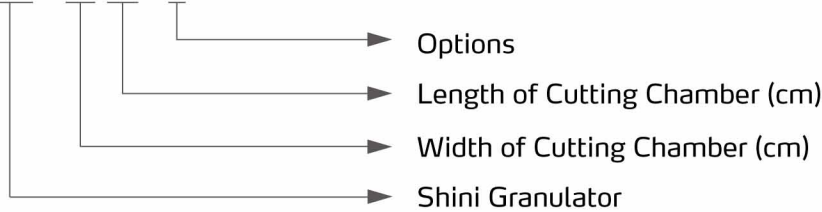

■ Features

● Fine finishing cutting chamber and cutting tools that need no adjustment

Components in the cutting chamber have been finely finished by CNC lathe, enjoying high accuracy; staggered cutters and structure can effectively disperse impact load and improve cutting efficiency; blade rest needing no adjustment makes it more convenient to change blades.

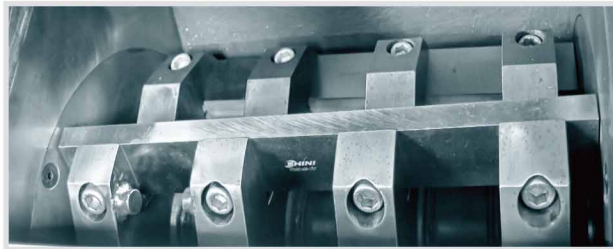

Cutting Chamber

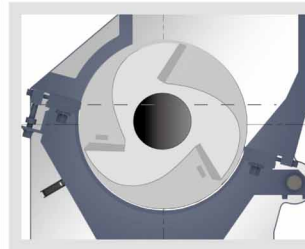

Two Fixed plus Three Rotating Blades(SG-43)

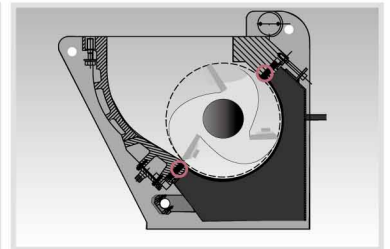

Two Fixed plus Three Rotating Blades(SG-50/70)

● Automatic conveying device

The machine is equipped with automatic conveying device of regrind materials, which is able to increase the conveying efficiency; materials are conveyed by blowers, which promote airflow and achieve air cooling of the cutting chamber to some extent. Thus, the room temperature of the cutting chamber can be reduced.



- **High-efficiency cutting motor**

The machine adopts IE3 high-efficiency motor, which has stable performance as well as safe operation and helps energy consumption.



- **Presetting Knife Jig**

The presetting knife jig, which enables to reshape of the blades and installation without too much cost and time.



- **Multiple safety protection of control**

Control circuit meets CE standard, and it has multiple protections including protection of motor overload, short circuit, phase default and phase order detection, ensuring safe operation of the machine.

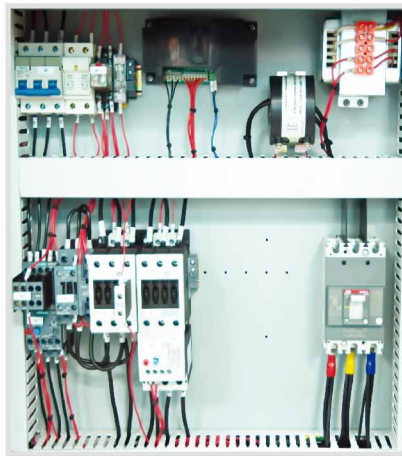

- **Sound-proofing machine**

The machine adopts enclosed sound-proof box, and in the positions that may make noises, there are sound-absorbing cotton, which can efficiently reduce the noises made in the cutting process.



- **Smart Energy-Saving Control System**

Compared to standard models and similar products on the market, this Smart Energy-Saving Control System can achieve 20% to 40% energy savings under identical working conditions.

The system features an integrated solid-state soft starter, which effectively reduces the motor's starting current and up to 70% of starting shock. This significantly lowers the motor's temperature rise, thereby extending its service life.



- **Cooling device of cutting chamber**

Cooling water device on the rear plate of cutting chamber can reduce the room temperature of cutting chamber and avoid the melt of regrind materials.

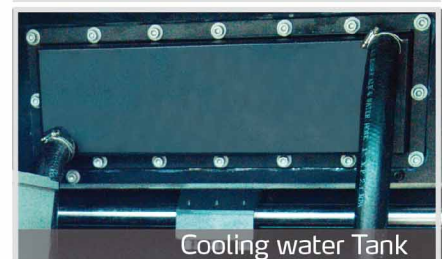

- **Application**

SG-43/50/70 series is suitable for centralized recycling of waste and rejected parts from injection, blowing molding and extrusion lines.

SG-43/50/70 Series

Options

Two Fixed plus Five Rotating Blades



Two fixed plus five rotating blades are optional with a small feed port of cutting chamber, suitable for granulating block and solid, thick sheet material. Suitable for SG-43.

Three Fixed plus Five Rotating Blades

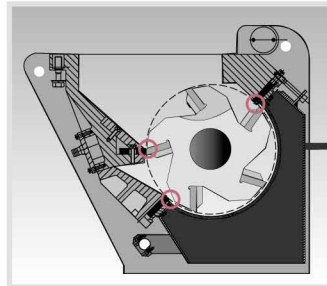

High cutting point fixed blades model has small inlet space and initially high cutting point. Thus its cutting force is not so strong, which enhances the reliability of cutting solid material. This design is suitable for granulating big solid material with thick wall and sheet.- Suitable for SG-50/70.

Feed Hopper with Magnet

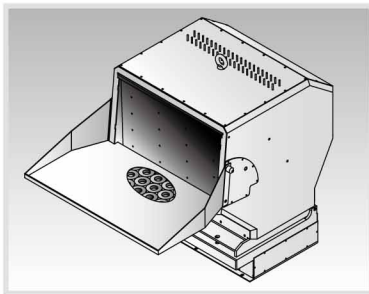

Feed hopper with magnet is used to take out metal craps and impurities in the material. (Except SG-70 series) Add "FHM" at the end of the model code.

Special Screens

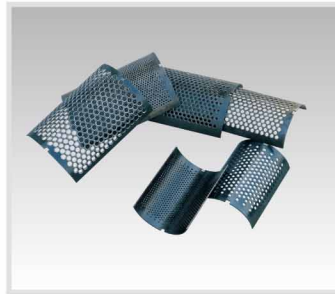

Φ8, Φ10, Φ17, Φ25(mm) are optional for SG-43;
Φ8, Φ10, Φ14, Φ17, Φ25 (mm) are optional for SG-50;
Φ10, Φ14, (mm) are optional for SG-70.
Add "SS + screen diameter" at the end of the model code, e.g.: Φ8mm , add "SS08".

Dust-separating system(SG-43)

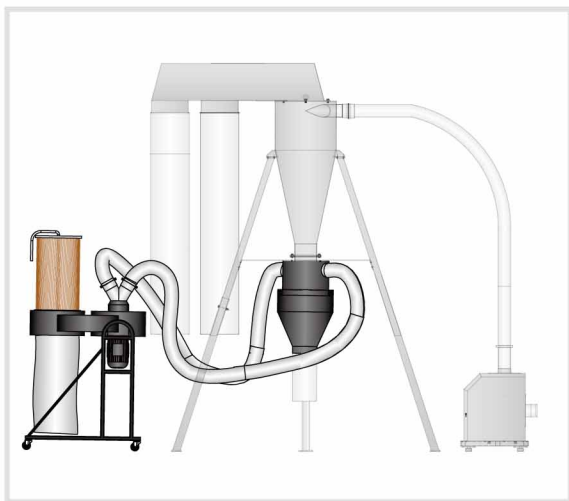

Dust-separating system(SG-50/70)

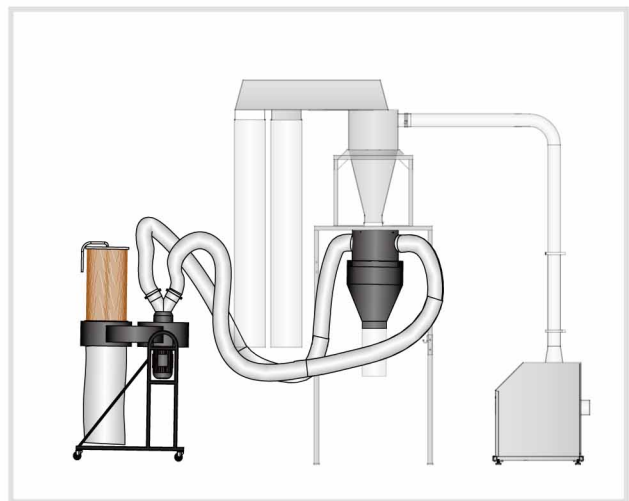

Optional dust-separating system to remove the dusts in the material. Add "DS" at the end of the model code.



Material Side Feed Pipe

The design of feeding hopper of traditional granulators is not suitable for longer pipes and section bars. We have designed material side feed pipe for convenient feeding of long materials. Add "SF" at the end of the model code.



Feeding Hopper for Conveyor

Material feeding for traditional large granulators is quite a difficult matter. They are generally installed at a lower place or a platform must be built for material feeding. Shini has particularly designed the belt conveyor to easily convey the material into the cutting chamber of SG-43 series. Add "BCF" at the end of the model code.

Full-receiver Alarm Device



Full-receive alarm device helps to achieve unmanned operation and no materials will be wasted. Whenever the regrind level reaches the motor position, the machine will be forced to stop and be cut off via it is sensor, thus stop the granulator and warn the user by sounding an alarm. Add "FAD" at the end of the model code.

Extended Feeding Hopper



In order to meet the needs of customers to Crush longer materials, such as car bumpers, optional Height-increasing storage bin (only suitable for SG-50/70). Add "FH" at the end of the model code.

- The function of fiber reinforced material granulating is optional. Adopt surface-hardening treatment on the material contacting component. And blade material is V-4E joint with S50C. Add "F" at the end of the model code.
- For stainless steel made feed hopper cover plate and storage tank, Add " R " at the end of the model code.
- Higher-power blower is optional, add "EC" at the end of the model code. (only suitable for SG-43)
- Higher-power motor is optional, add "H" at the end of the model code.(only suitable for SG-43)

SG-43/50/70 Series

Outline Drawings (SG-43)

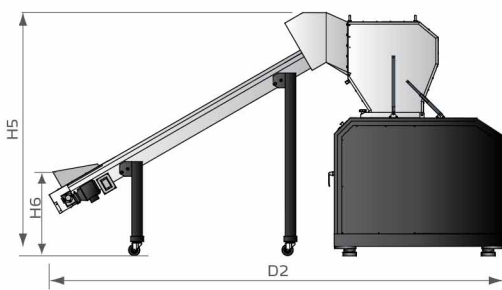
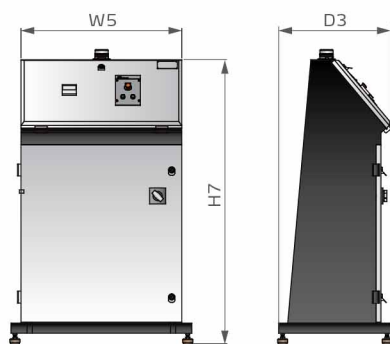
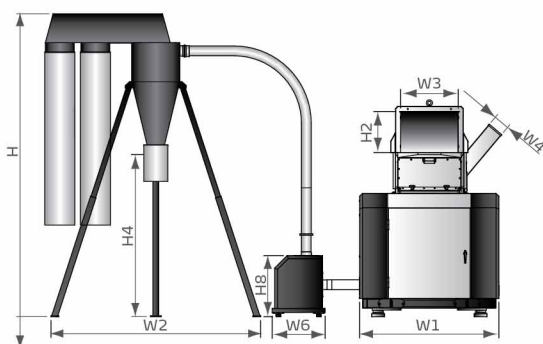
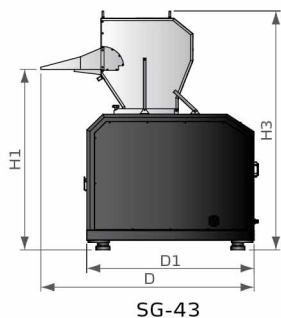

Specifications(SG-43)

Model	SG-4360(H)	SG-4390(H)	
Motor Power (kW, 50/60Hz)	30/34 (37/41.5)	37/41.5 (45/51)	
Conveying Blower (kW, 50/60Hz)	2.2/2.55	2.2	
Rotating Speed (rpm, 50/60Hz)	525/630	525/630	
Quantity of Fixed Blades	2 x 1	2 x 2	
Quantity of Rotating Blades(Optional)	3 x 1 (5 x 1)	3 x 2 (5 x 2)	
Cutting Chamber	mm	430 x 600	
	inch	16.9 x 23.6	
Max. Output	kg/hr	800	
	lb/hr	1764	
Noise Level dB(A)	105-110	105-110	
Material of Blades	SKD11	SKD11	
Screen	φ12 mm/0.47"	φ12 mm/0.47"	
Higher-power blower (kW)	○(7.5)	○(7.5)	
Dimensions	H (mm)	mm	2710-3155
		inch	106.7-124.2
	H1 (mm)	mm	1708
		inch	67.2
	H2 (mm)	mm	430
		inch	16.9
	H3 (mm)	mm	2260
		inch	89
	H4 (mm)	mm	1240-1690
		inch	48.8-66.5
	H5 (mm)	mm	2277
		inch	89.6
	H6 (mm)	mm	750
		inch	29.5
	H7 (mm)	mm	1416
		inch	55.8
	H8 (mm)	mm	636(970)
		inch	25(38.2)
	W1 (mm)	mm	1450
		inch	57
W2 (mm)	mm	1900-2310	
	inch	74.8-90.9	
W3 (mm)	mm	600	
	inch	23.6	
W4 (mm)	mm	166x 166	
	inch	6.5 x 6.5	
W5 (mm)	mm	800	
	inch	31.5	
W6 (mm)	mm	552(630)	
	inch	21.7(24.8)	
D (mm)	mm	1978	
	inch	77.9	
D1 (mm)	mm	1553	
	inch	61	
D2 (mm)	mm	4300	
	inch	165.4	
D3 (mm)	mm	560	
	inch	22	
Weight	kg	2350 (2430)	
	lb	5181 (5357)	
		2730 (2780)	
		6019 (6129)	

Notes: 1) "○" stands for optional.

2) SKD11 is steel grade of Japanese JIS standard.

3) Max. capacity of the machine is subject to diameter of screen mesh and composition of the material.

4) Noise level varies with different materials and motor types.

5) Noise level is tested under conditions of 1m around the machine and 1.6m from the ground.

6) Power supply : 3Φ, 230/400/460/575VAC, 50/60Hz.

Outline Drawings(SG-50)

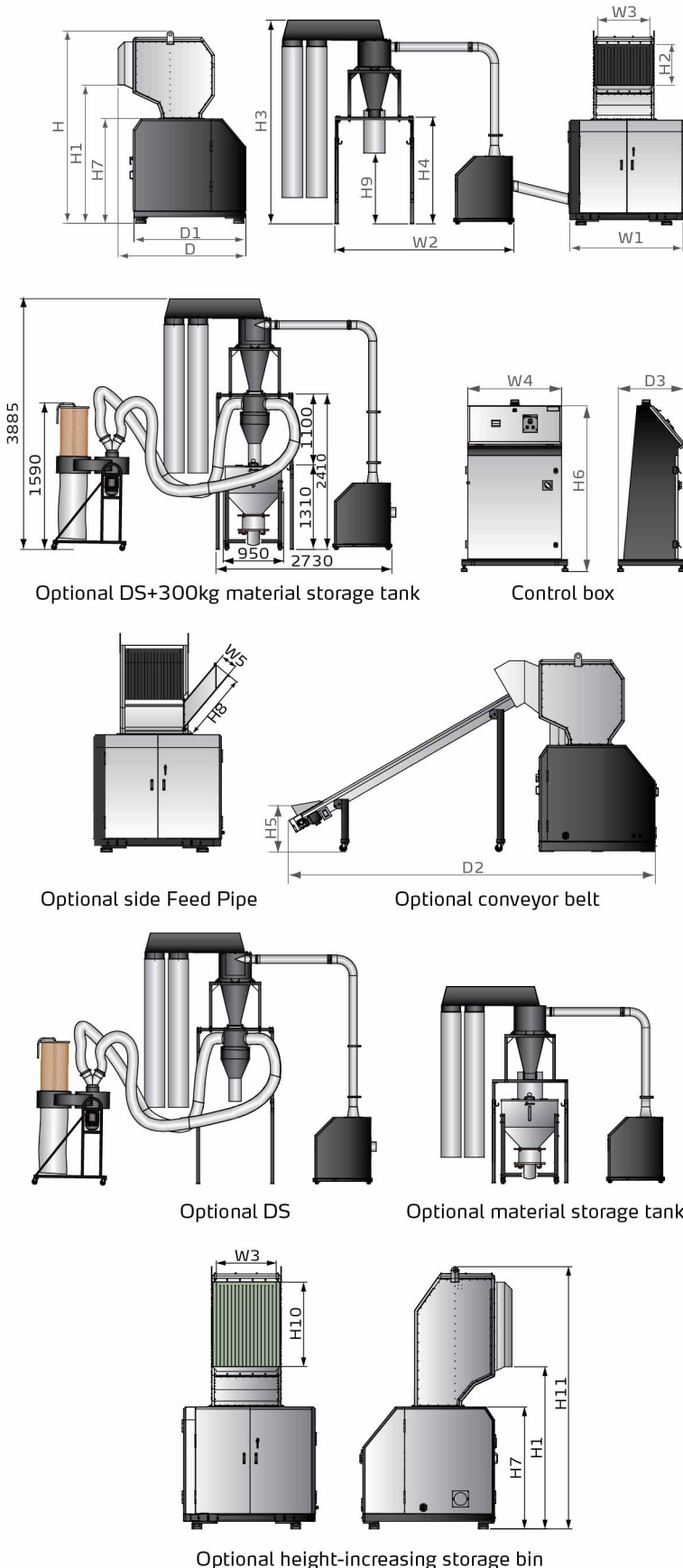

Specifications(SG-50)

Model	SG-5080	SG-50110	
Motor Power (kW, 50/60Hz)	37	45	
Rotating Speed (rpm, 50/60Hz)	525		
Conveying Blower (kW, 50/60Hz)	7.5		
Handspike Motor Power (kW, 50/60Hz)	0.25		
Material of Blades	SKD11		
Quantity Fixed Blades (optional)	2×2 (3×2)	2×2 (3×2)	
Quantity of Rotating Blades	3×2 (5×2)	3×2 (5×2)	
Cutting Chamber	500x800	500x1100	
Max. Output	1100	1500	
Noise Level dB(A)	105-110		
Screen	Φ12mm/0.47"		
Dimension	H	mm 2980	2980
		inch 117.3	117.3
	H1	mm 2170	2170
		inch 85.1	85.1
	H2	mm 620	620
		inch 24.4	24.4
	H3	mm 3100	3100
		inch 122	122
	H4	mm 1625	1625
		inch 64	64
	H5	mm 700	700
		inch 27.6	27.6
	H6	mm 1416	1416
		inch 55.8	55.8
	H7	mm 1630	1630
		inch 64.2	64.2
	H8	mm 394	394
		inch 15.5	15.5
	H9	mm 1077	1077
		inch 42.4	42.4
	H10	mm 1120	1120
		inch 44.1	44.1
H11	mm 3480	3480	
	inch 137	137	
D	mm 2000	2000	
	inch 78.7	78.7	
D1	mm 1740	1740	
	inch 68.5	68.5	
D2	mm 5470	5470	
	inch 215.4	215.4	
D3	mm 560	560	
	inch 22	22	
W1	mm 1740	2040	
	inch 68.5	80.3	
W2	mm 2730	2730	
	inch 107.5	107.5	
W3	mm 800	1100	
	inch 31.5	43.3	
W4	mm 800	800	
	inch 31.5	31.5	
W5	mm 215x215	215x215	
	inch 8.5x8.5	8.5x8.5	
Weight	kg 4060	4710	
	ib 8951	10384	

- Notes:
- 1) SKD11 is steel grade of Japanese JIS standard.
 - 2) Maximum throughput of granulator is subject to the diameter and material of screen mesh. For granulating frame and shell materials, maximum throughput will be reduced about half.
 - 3) Noise level varies with different materials and motor types.
 - 4) Noise level is tested under conditions of 1m around the machine and 1.6m from the ground.
 - 5) To avoid plastic form sticking to the blades, all materials should be crushed at normal temperature.
 - 6) Power supply : 3Φ, 230/400/460/575VAC, 50/60Hz.

SG-43/50/70 Series

Outline Drawings(SG-70)

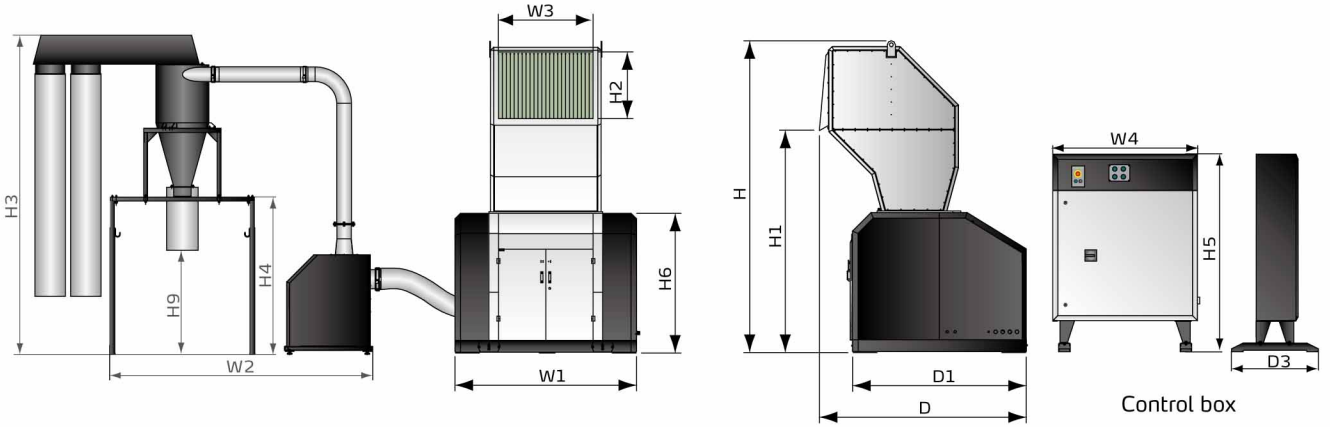

Control box

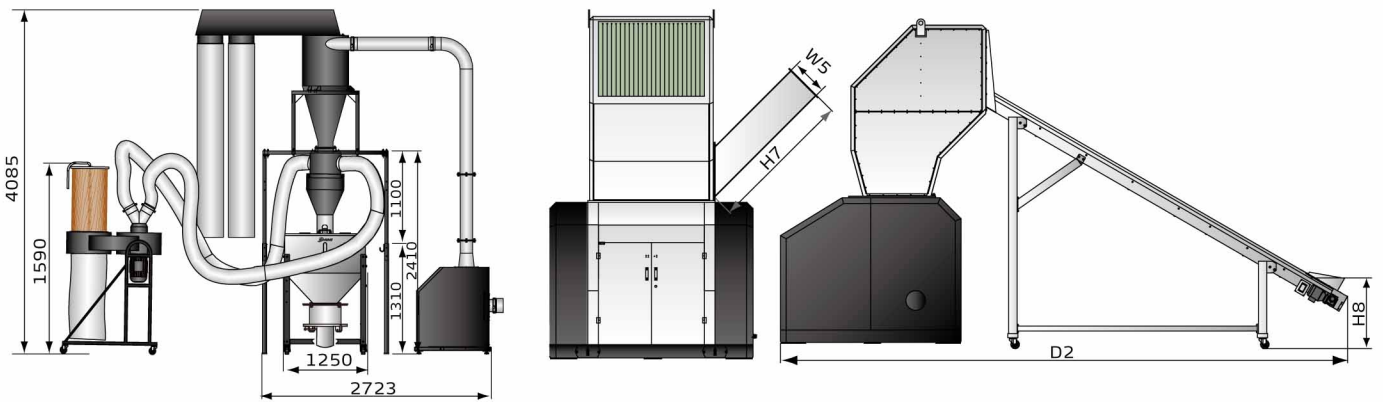

Optional DS+500kg material storage tank

Optional side Feed Pipe

Optional conveyor belt

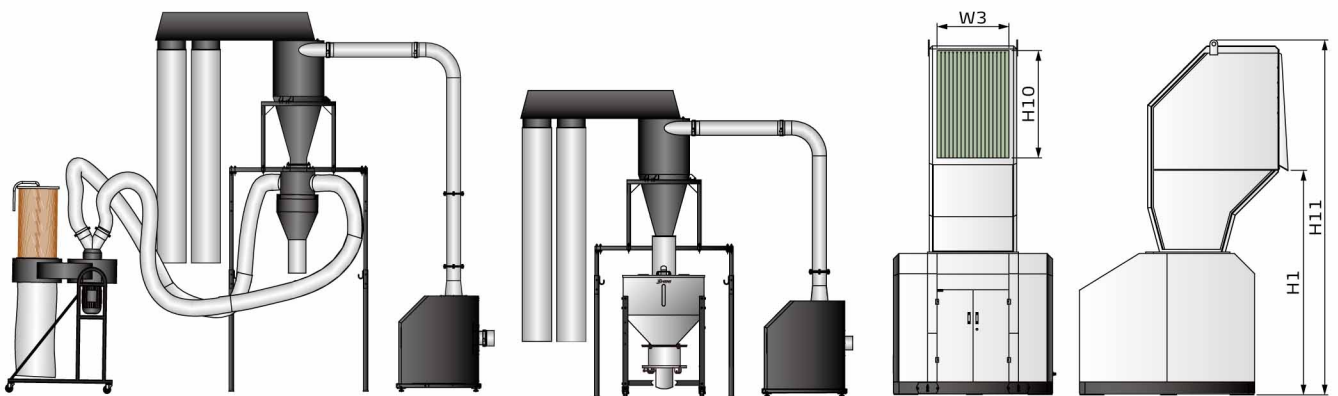

Optional DS

Optional material storage tank

Optional height-increasing storage bin



Specifications(SG-70)

Model		SG-7090	SG-70120
Motor Power (kW, 50/60Hz)		75	90
Rotating Speed (rpm, 50/60Hz)		525	525
Conveying Blower (kW, 50/60Hz)		7.5/8.6	7.5/8.6
Handspike Motor Power (kW, 50/60Hz)		1.5	1.5
Material of Blades		SKD11	SKD11
Quantity of Fixed Blades (Optional)		2×2 (3×2)	2×2 (3×2)
Quantity of Rotating Blades (Optional)		3×2 (5×2)	3×2 (5×2)
Cutting Chamber		mm	700 × 900
		inch	27.6 × 35.4
Max. Output		kg/hr	1300
		lb/hr	2866
Noise Level dB(A)		115	115
Dimension	H (mm)	mm	3950
		inch	155.5
	H1 (mm)	mm	2815
		inch	110.8
	H2 (mm)	mm	840
		inch	33
	H3 (mm)	mm	3100
		inch	122
	H4 (mm)	mm	1625
		inch	64
	H5 (mm)	mm	1370
		inch	53.9
	H6 (mm)	mm	1770
		inch	69.7
	H7 (mm)	mm	1419
		inch	55.9
	H8 (mm)	mm	846
		inch	33.3
	H9 (mm)	mm	1077
		inch	42.4
	H10 (mm)	mm	1340
		inch	52.8
	H11 (mm)	mm	4450
		inch	175.2
	W1 (mm)	mm	2000
		inch	78.7
	W2 (mm)	mm	2730
		inch	107.5
W3 (mm)	mm	900	
	inch	35.4	
W4 (mm)	mm	1000	
	inch	39.3	
W5 (mm)	mm	350x350	
	inch	13.8x13.8	
D (mm)	mm	2630	
	inch	103.5	
D1 (mm)	mm	2200	
	inch	86.6	
D2 (mm)	mm	6840	
	inch	269.3	
D3 (mm)	mm	600	
	inch	23.6	
Weight (kg)		kg	4500
		lb	9,921

Notes: 1) SKD11 is steel grade of Japanese JIS standard.

2) Maximum output is subject to the diameter and material of screen mesh. For granulating frame and shell material, maximum output will be reduced about 50%.

3) Noise level varies with different materials and motor type.

4) Noise level is tested under conditions of 1m/39.9' around the machine and 1.6m/63' from the ground.

5) To avoid plastics from sticking to the blades, all materials should be crushed at normal temperature.

6) Power supply: 3Φ, 230/400/460/575VAC, 50/60Hz.